

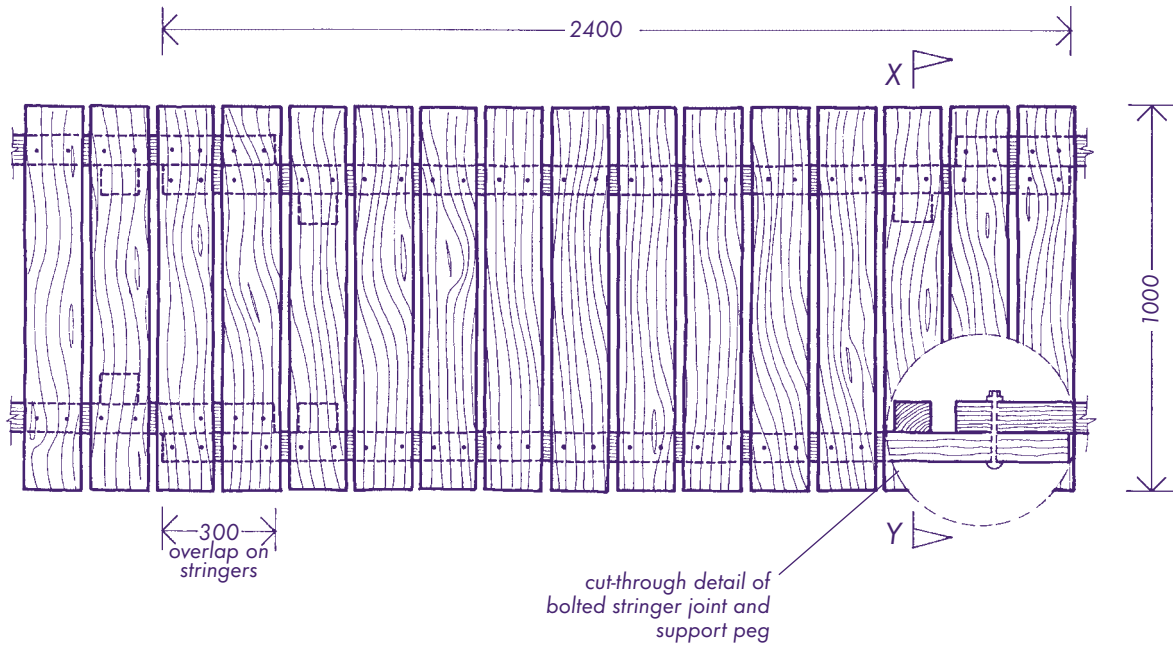

6.1A Plan
Scale 1:20
0 1000mm

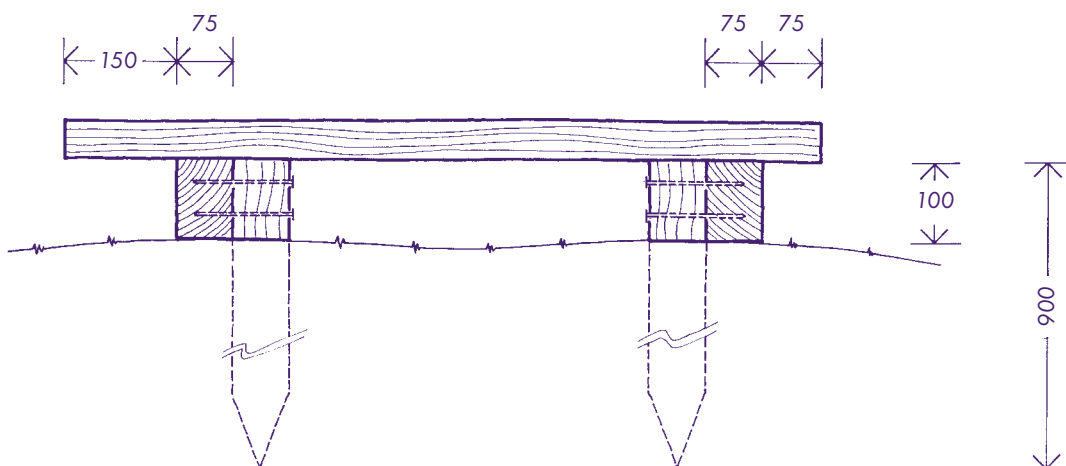

6.1B Section X-Y
Scale 1:10
0 500mm



Boardwalk Purpose

Reducing Visitor Pressure on Sensitive Habitats	Providing Visitor Access across Water & Wetlands	Suitability for Use by Able-Bodied People	Suitability for Use by People with Mobility Difficulties	Suitability for Wheelchair Users
✓	✗	☺	☹	☹

